



EQUIPMENT RACK ACCESSORIES

Jumper Trays:

- Provides ANSI/TIA/EIA-568A 1-1/2" bend radius compliance for Cat 5
- Slotted holes allow adjustment of cable runs
- Telescopes to allow adjustment of cable entry position
- Easy installation using a simple bolt on method, mounting screws included
- Formed aluminum construction
- Sold individually
- Choice of colors: *Color Code* = "x" Black (BLK) or ASA 61 Gray (G)

Part #	Description
SWE2183-19x	Upper Jumper Tray 19" RM
SWE2183-23x	Upper Jumper Tray 23" RM
SWE2185-19x	Lower Jumper Tray 19" RM
SWE2185-23x	Lower Jumper Tray 23" RM

Transition Plate: *SWE2186*

- Provides transition between adjoining racks
- Slotted holes allow adjustment of cable runs
- Formed aluminum construction
- Choice of colors: *Color Code* = "x" Black (BLK) or ASA 61 Gray (G)

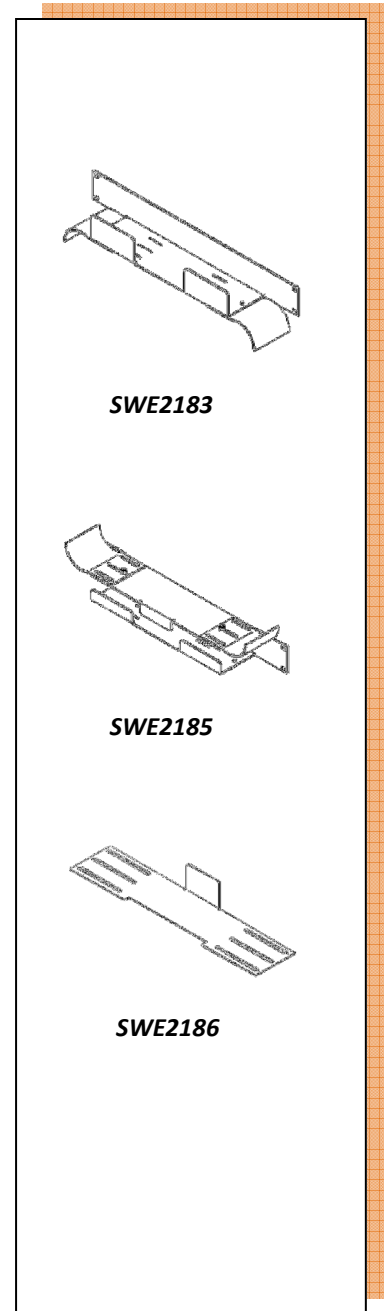



EQUIPMENT RACK ACCESSORIES cont'd

Rack Dolly Wheels:

SWE2175

- One piece construction for strength
- Available for 19" and 23" RM 2-Post Equipment Racks (add "-23" to part number e.g. SWE2175-23BLK)
- Allows rack to be moved to provide total access to all sides
- Casters include wheel locks
- Fully welded plate steel construction
- Load capacity 600 lbs.
- Hardware included
- Choice of colors: *Color Code* = "x" Black (BLK) or ASA 61 Gray (G)

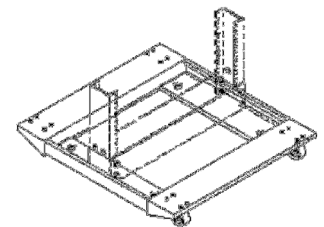

SWE2175

SWE2554

- Two piece construction fits any 2-Post equipment rack
- Allows rack to be moved to provide total access to all sides
- Casters include wheel locks
- Fully welded plate steel construction
- Load capacity 600 lbs.
- Hardware included
- Choice of colors: *Color Code* = "x" Black (BLK) or ASA 61 Gray (G)

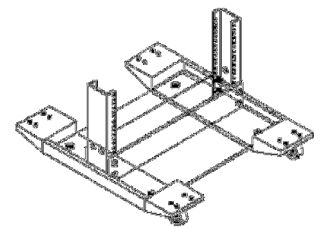

SWE2554



EQUIPMENT RACK ACCESSORIES cont'd

Standoff Tie Bracket: SWE2559

- Provides a mounting surface on back of rack channel to tie down cable runs
- Formed aluminum construction
- Mounting screws included
- Sold individually
- Choice of colors: *Color Code* = "x" Black (BLK) or ASA 61 Gray (G)

Universal Earthquake Brace Kit: SWE2562

- Provides an adjustable brace to secure equipment rack to wall or ceiling
- Threaded rod *not* included
- Kit contains:
 - (4) Brackets (makes 2 swivel brackets)
 - (2) ½"-13 x 1-1/4" bolts
 - (2) ½" -13 hex nuts
 - (2) ½" split washers

Concrete Floor Rack Installation Kit SWE2604

- Hardware to secure all SWDP racks to concrete floor
- For use with 19" and 23" RM racks
- Kit contains:
 - (4) 3/8"-16 concrete anchors
 - (4) 3/8"-16 x 3-1/2" studs
 - (4) 3/8" split washers
 - (4) 3/8"-16 hex nuts
 - 3/8" fender washers

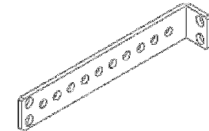

SWE2559

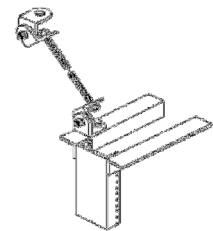

SWE2562

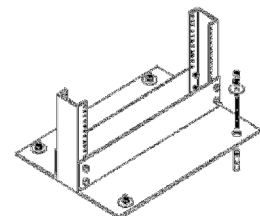

SWE2604



EQUIPMENT RACK ACCESSORIES cont'd

Raised Floor Support Kit

- Provides support for equipment racks installed on raised floor systems
- Available in 4 adjustable heights
- Includes pre-cut threaded rods, brackets and all necessary hardware

Part #	Description
SWE2632-12	Adjusts from 4" – 12"
SWE2632-20	Adjusts from 13" – 20"
SWE2632-28	Adjusts from 21" – 28"
SWE2632-36	Adjusts from 29" – 36"

Rack Mount Grounding Bar SWE2610

- Rack mounted equipment grounding bar
- Available in 19" and 23" RM (add "-23" to part number for 23" RM)
- #12-24 tapped lug mounting holes on 1" centers
- Kit contains:
 - (1) 19" x 1" copper ground bar
 - (1) 2.5" x 1" splice plate
 - (2) #12-24x3/4" screws
 - (8) #12-24x1/2" screws

Rack Mounted Block Mounting Bar SWE2901

- Provides rack mounting for terminal blocks (66 and 110 types) and other equipment
- #12-24 tapped holes provide an infinite combination of mounting Possibilities
- Available in 19" or 23" RM
- Constructed from heavy duty cold roll steel angle
- Zinc plated or powder coat Black finish
- *Sold individually*

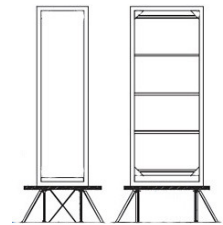

Raised Floor Support Kit

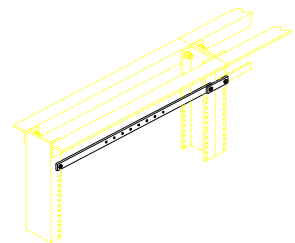

SWE2610

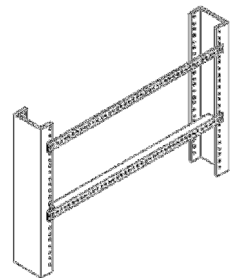

SWE2901



EQUIPMENT RACK ACCESSORIES cont'd

Blank Filler Panels:

- 19" wide rack mount units
- Mounting slots on EIA standard spacing
- Constructed from 16 gauge carbon steel
- Black powder coat finish

Part #	RMU
SWE651BLK	1 RU (1.75")
SWE652BLK	2 RU (3.5")
SWE653BLK	3 RU (5.25")
SWE654BLK	4 RU (7.0")
SWE655BLK	5 RU (8.75")
SWE656BLK	6 RU (10.5")
SWE657BLK	7 RU (12.25")
SWE658BLK	8 RU (14.0")
SWE659BLK	19RU (15.75")

Reducers:

- Converts 23" RM to 19" RM
- Holes tapped #10-32 on EIA standard spacing
- 14 gauge carbon steel construction
- Includes mounting hardware
- Sold in pairs
- Gold Zinc plated

Part #	RMU
SWE851GZ	1 RU (1.75")
SWE852GZ	2 RU (3.5")
SWE853GZ	3 RU (5.25")

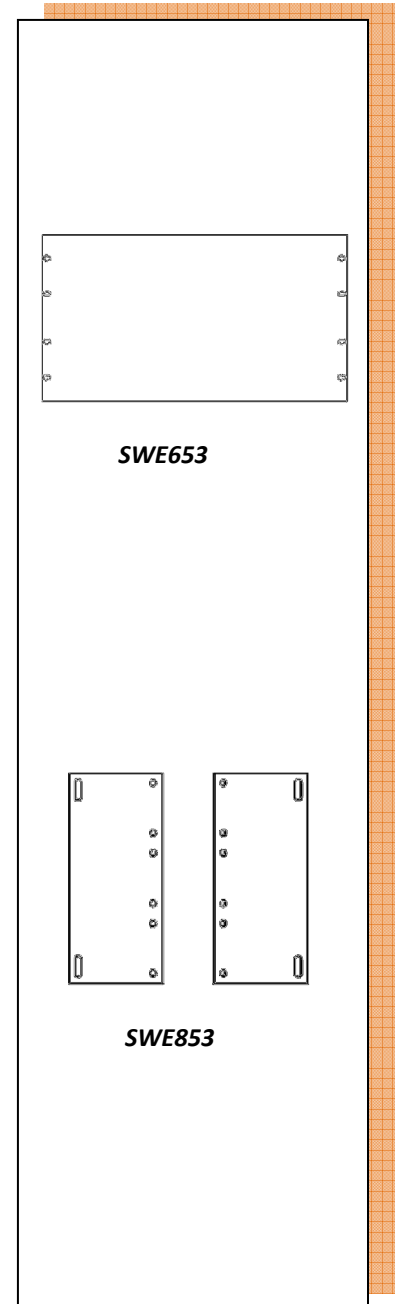

EQUIPMENT RACK ACCESSORIES cont'd

Power Strips:

SWE2070 Series

- Mounts vertically to equipment rack
- 15 AMP or 20 AMP rating with circuit breaker
- UL listed
- 48" long with 15' cord
- Mounting hardware included

Part #	Description
SWE2070	16 Outlet, 15 AMP w/Mounting Brackets
SWE2070-20A	14 Outlet, 20 AMP w/Mounting Brackets

SWE705-RM

- 19" RM unit
- 15 Amp rating with circuit breaker
- 8 outlet power distribution (6 front, 2 rear)
- One RMU high
- UL listed
- 15' cord
- Mounting hardware included

SWE705-20R-RM

- 19" RM unit
- 20 Amp rating with circuit breaker
- 8 outlet power distribution (6 front, 2 rear)
- 20 Amp receptacles (5-20R)
- 15' cord with L5-20P twist lock plug on cord end
- UL listed

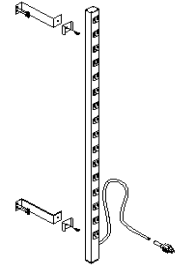

SWE2070

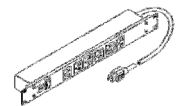

SWE705-RM

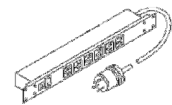

SWE705-20R- RM



EQUIPMENT RACK ACCESSORIES cont'd

2 Post Server Mounting Brackets

- Can be installed on any 2 Post Equipment Rack with 3" upright channels
- Available in 3 heights
- Depth adjustable from 10" to 32" – supports equipment up to 35" long
- Flush mount or center mount options
- Cable management bar included
- Steel construction
- Black Powder Coat finish

Part Number	Wt. Capacity – Flush Mt.	Wt. Capacity – Center Mt.
100538-1U	30 lbs	45 lbs
100538-2U	50 lbs	75 lbs
100538-3U	125 lbs	200 lbs

2 Post Rack Conversion Kit

- Available in 2U and 3U heights
- Compatible with 3" upright channels
- Easily provides 4 Post mounting requirements to a 2 Post Equipment Rack
- Can be coupled together to utilize the entire rack or any portion needed
- Kit includes (4) conversion brackets which will create a standard 4 Post Equipment Rack depth
- Steel construction
- Black Powder Coat finish

Part Number	Installed Dimensions
SWE582-2	3.5"H x 29-1/8"D
SWE582-3	5.25"H x 29-1/8"D

