



**EQUIPMENT RACK SHELVES**

- 19" or 23" rack mounting units
- Formed steel or aluminum construction for strength
- Clear brushed shelves are formed aluminum construction
- Mounting holes on EIA standard spacing
- Choice of colors: *Color Code* = "x" Black (BLK), ASA 61 Gray (G) or Clear (CLR)

**Single Sided Shelves:**

19" RM	23" RM	Depth	Wt. Capacity
SWE2117x**	SWE2117-23x**	15"	50 lbs.
SWE595-19-10x	SWE595-23-10x	10"	50 lbs.
SWE595-19-12x	SWE595-23-12x	12"	50 lbs.
SWE595-19-14x	SWE595-23-14x	14"	50 lbs.
SWE595-19-20x	SWE595-23-20x	20"	50 lbs.
SWE596-19-10x	SWE596-23-10x	10"	100 lbs.
SWE596-19-15x	SWE596-23-15x	15"	100 lbs.
SWE596-19-20x	SWE596-23-20x	20"	100 lbs.

**Note: \*\* Indicates Aluminum construction shelf**

**Double Sided Shelf Set**

19" RM	23"RM	Depth	Wt. Capacity
SWE2054x**	SWE2054-23x**	26"	150 lbs.
SWE2108x**	SWE2108-23x**	21-3/4"	100 lbs.
SWE2108STLx	SWE2108-23STLx	21-3/4"	100 lbs.
SWE2164x**	SWE2164-23x**	20"	200 lbs.
SWE2231x**	SWE2231-23x**	21-3/4"	100 lbs.
SWE596-19-BBx	SWE596-23-BBx	30"	150 lbs.

**Note: \*\* Indicates Aluminum construction shelf**

**Center Weight Shelves**

19" RM	23"RM	Depth	Wt. Capacity
SWE2245x**	SWE2245-23x**	18"	110 lbs.
SWE597-19-11x	SWE597-23-11x	11"	100 lbs.
SWE597-19-15x	SWE597-23-15x	15"	100 lbs.
SWE597-19-19x	SWE597-23-19x	19"	100 lbs.
SWE598-19-19x	SWE598-23-19x	19"	50/75 lbs.

**Note: \*\* Indicates Aluminum construction shelf**

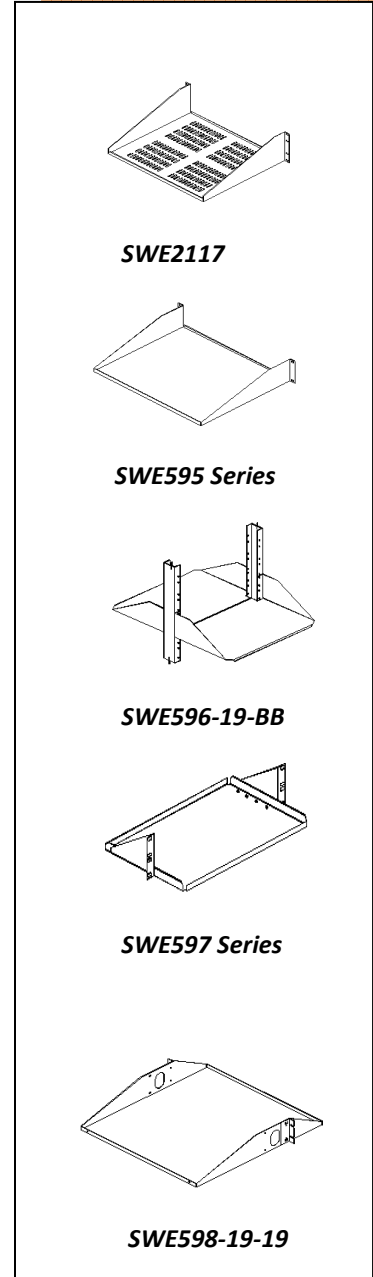



---

---

**EQUIPMENT RACK SHELVES cont'd**

**Keyboard Trays:**

**Sliding Single Keyboard Tray SWE2062**

- 19" or 23" rack mount
- Formed aluminum construction
- Mounting holes on EIA standard spacing
- Tray extends 8" to provide full access to keyboard
- 19" version holds up to 16.1" wide keyboard
- 23" version holds up to 20.1" wide keyboard
- Add "-23" to part number for 23" RM shelf
- Choice of colors: *Color Code* = "x" Black (BLK), ASA 61 Gray or Clear Brushed (CLR)

**Tilting Keyboard Tray SWE2163**

- 19" or 23" rack mount
- Formed aluminum construction
- Tray extends 9" to provide full access to keyboard
- Retracts when not in use
- Tray tilts after extension to provide better viewing angle and access
- 19" version holds up to 16.1" wide keyboard
- 23" version holds up to 20.1" wide keyboard
- Add "-23" to part number for 23" RM shelf
- Choice of colors: *Color Code* = "x" Black (BLK), ASA 61 Gray or Clear Brushed (CLR)

*Note: Add color code to part number when ordering  
e.g. SWE2062-23BLK*

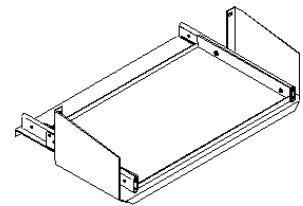

**SWE2062**

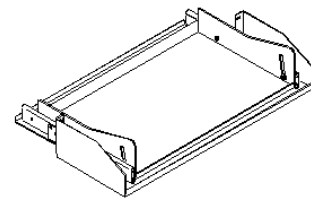

**SWE2163**



---

---

**EQUIPMENT RACK SHELVES cont'd**

**Keyboard Trays (cont'd):**

**Full Size sliding Keyboard & Mouse Tray *SWE2193***

- 19" or 23" rack mount
- Add "-23" to part number for 23" RM version
- Formed aluminum construction
- Tray extends 9" to provide full access to keyboard
- Retracts when not in use
- Fits up to 19.25" wide x 9" deep keyboards
- Retractable mouse tray included
- Choice of colors: *Color Code* = "x" Black (BLK), ASA 61 Gray or Clear Brushed (CLR)

**Sliding Double Keyboard Tray *SWE2227***

- 19" or 23" rack mount
- Formed aluminum construction
- Mounting holes on EIA standard spacing
- Tray extends 8" to provide full access to keyboard
- Retracts when not in use
- 19" version holds up to 16.1" keyboard
- 23" version holds up to 20.1" keyboard
- Choice of colors: *Color Code* = "x" Black (BLK), ASA 61 Gray or Clear Brushed (CLR)

*Note: Add color code to part number when ordering  
e.g. SWE2193-23BLK*

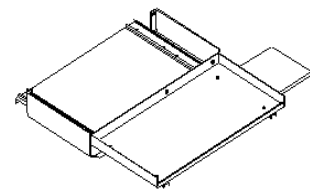

***SWE2193***

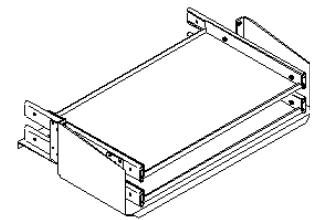

***SWE2227***



---

---

**EQUIPMENT RACK SHELVES cont'd**

**Double Sided Heavy Duty CPU / Monitor Shelf    *SWE2487*  
w/Sliding Keyboard Tray**

- 19" or 23" rack mount
- Formed aluminum construction
- Shelves are 10" deep each, or 20" deep when mounted back-to-back
- Keyboard tray extends 8.6"
- 19" rack mount version must use small footprint keyboard
- Add "-23" to part number for 23" rack mount version
- 100 lb. weight capacity per shelf or 200 lb. total per set
- Choice of colors: *Color Code* = "x" Black (BLK), ASA 61 Gray or Clear Brushed (CLR)

**Double Sided Heavy Duty CPU / Monitor Shelf    *SWE2488*  
w/Double Sliding Keyboard Tray**

- 19" or 23" rack mount
- Formed aluminum construction
- Shelves are 10" deep each, or 20" deep when mounted back-to-back
- Dual keyboard tray extends 8.6"
- 19" rack mount version must use small footprint keyboard
- Add "-23" to part number for 23" rack mount version
- 100 lb. weight capacity per shelf or 200 lb. total per set
- Choice of colors: *Color Code* = "x" Black (BLK), ASA 61 Gray or Clear Brushed (CLR)

*Note: Add color code to part number when ordering  
e.g. SWE2487-23BLK*

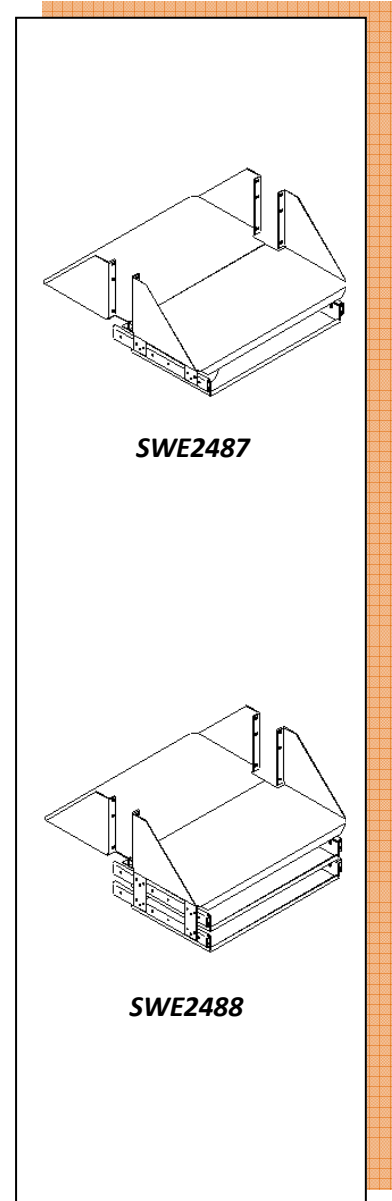



**EQUIPMENT RACK SHELVES cont'd**

**Dual Rack Adjustable Shelves**

- 19" four post rack mount
- Formed 16 gauge steel construction
- Shelves adjustable to fit specific rack depth
- Vented and non-vented styles available
- 200 lb. weight capacity
- Mounts to all four uprights
- Black powder coat finish

Part #	Fits Rack #	Adjustable Depth
SWE1520BLK	SWE04-841520BLK	15" to 20"
SWE2126BLK	SWE04-842126BLK	21" to 26"
SWE2732BLK	SWE04-842732BLK	27" to 32"
<b>Note: Add "-V" to part number for vented version e.g. SWE1520-VBLK</b>		

**Multi-Mount Equipment Shelves**

- 19" rack mount
- Formed 16 gauge steel construction
- Vented and non-vented versions available
- Adjustable mounting brackets provide for 3 different rack mounting positions
- 150 lb. weight capacity
- Choice of colors: *Color Code* = "x" Black (BLK) or ASA 61 Gray

Part #	Version	Depth
SWE191x	Non-Vented	11.5"
SWE191-Vx	Vented	11.5"
SWE193	Non-Vented	15.5"
SWE193-Vx	Vented	15.5"
SWE194x	Non-Vented	21.75"
SWE194-Vx	Vented	21.75"

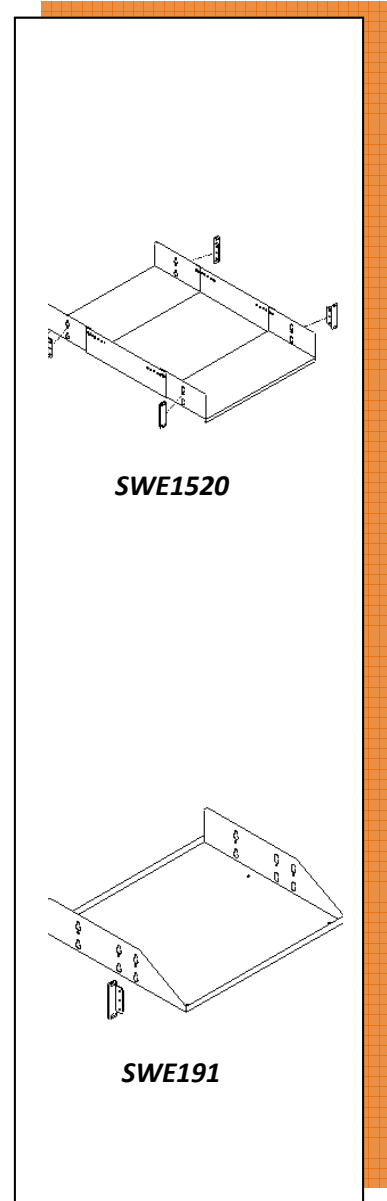



**EQUIPMENT RACK SHELVES cont'd**

**Multi-Configured Equipment Shelf SWE2248**

- 19" rack mount
- Multiple configurations include rack and wall mount options
- 17.5" wide x 12" deep
- Uses 3 RMU of space
- Formed 16 gauge steel construction
- 50 lb. weight capacity
- Choice of colors: *Color Code* = "x" Black (BLK) or ASA 61 Gray

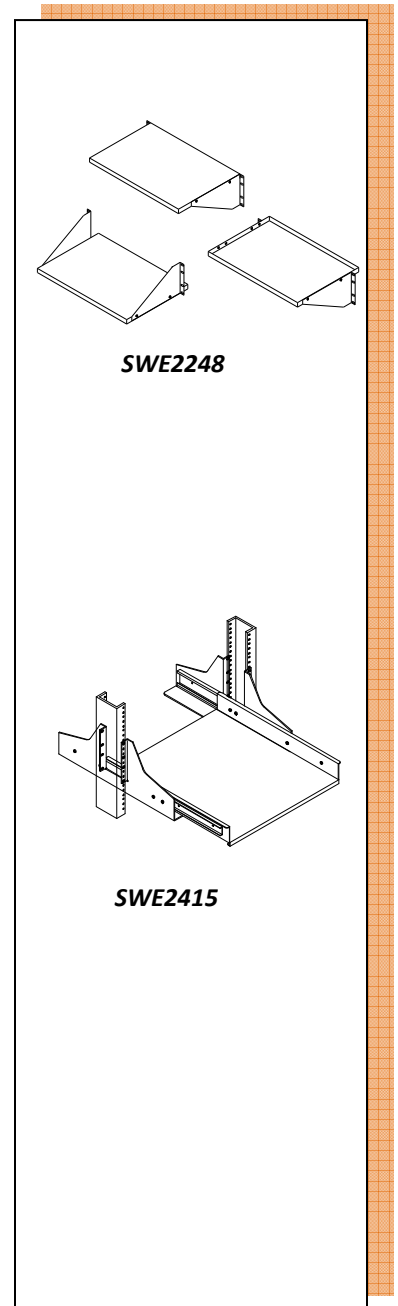

**SWE2248**

**SWE2415**

**Sliding Equipment Shelf SWE2415**

- 19" or 23" rack mount
- Formed steel construction
- Shelf depth of 18"
- 100 lb. weight capacity
- Choice of colors: *Color Code* = "x" Black (BLK) or ASA 61 Gray

Part #	Description	Wt. Capacity
SWE2415x	16"W X 18"D (19" RM)	100 lbs
SWE2415-23x	20"W X 18"D (23" RM)	100 lbs